

USING TECHNOLOGY TO REPRESENT MATHEMATICAL IDENTITIES

by: Charles L. Hamberg and Richard Kick
Illinois Mathematics and Science Academy

The role of technology continues to expand in the way both mathematics teachers and mathematics students implement its uses. Mathematics teachers often use a graphing calculator or computer to graph equivalent trigonometry functions, therefore, helping students intuitively develop their belief of an identity relationship.

In the examples below *Mathematica* is used to intuitively convince students that the functions $\sin 2x$ and $2 \sin x \cos x$ could establish the identity

$\sin 2x = 2 \sin x \cos x$. Similarly the graphs of $\cos 2x$, $(\cos x)^2 - (\sin x)^2$, $1 - 2(\sin x)^2$, and $2(\cos x)^2 - 1$ would suggest the identities

$$\cos 2x = (\cos x)^2 - (\sin x)^2 = 1 - 2(\sin x)^2 = 2(\cos x)^2 - 1.$$

`Plot[Sin[2x], {x, -Pi, Pi}]`

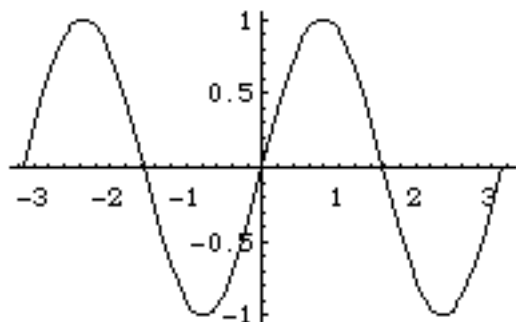

`Plot[2 Sin[x] Cos[x], {x, -Pi, Pi}]`

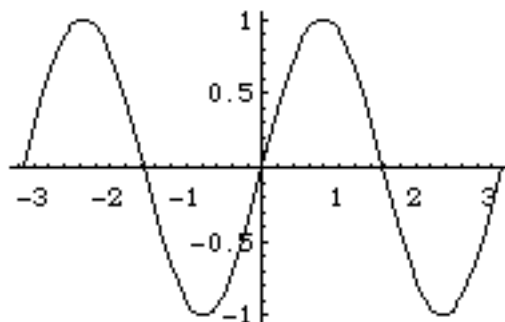

Each *Mathematica* statement listed will produce the graph shown.

`Plot[Cos[2x], {x, -Pi, Pi}]`

`Plot[1-2Sin[x]^2, {x, -Pi, Pi}]`

`Plot[Cos[x]^2-Sin[x]^2, {x, -Pi, Pi}]`

`Plot[2Cos[x]^2-1, {x, -Pi, Pi}]`

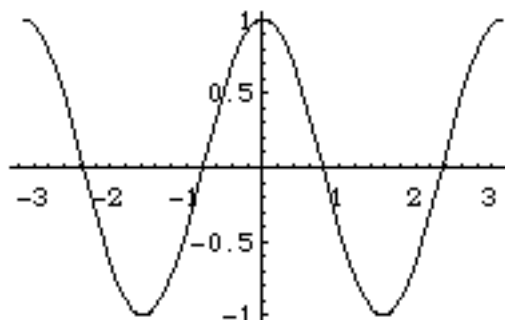

The capabilities of *Mathematica* to visually represent 3-space graphs provides students with a powerful intuitive, visual representation of possible identities such as:

$$\sin(x + y) = \sin x \cos y + \sin y \cos x$$

$$\sin(x - y) = \sin x \cos y - \sin y \cos x$$

$$\cos(x + y) = \cos x \cos y - \sin x \sin y$$

$$\cos(x - y) = \cos x \cos y + \sin x \sin y$$

$$\tan(x + y) = \frac{\tan x + \tan y}{1 - \tan x \tan y}$$

$$\tan(x - y) = \frac{\tan x - \tan y}{1 + \tan x \tan y}$$

The graphs that follow make reference to the above identities.

```
Plot3D[Sin[x+y],
{x,-2Pi,2Pi},{y,-2Pi,2Pi}]
```

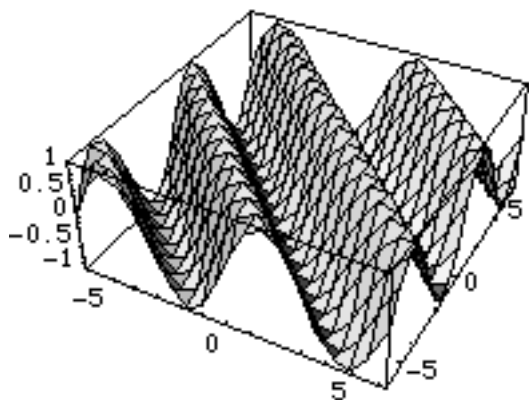

```
Plot3D[Sin[x] Cos[y] +
Cos[x] Sin[y],
{x,-2Pi,2Pi},{y,-2Pi,2Pi}]
```

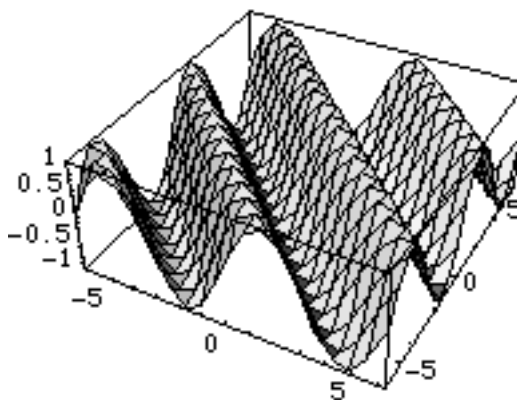

Each of the following graphs are obtained from 2 different plot commands.

```
Plot3D[Sin[x-y],
{x,-2Pi,2Pi},{y,-2Pi,2Pi}]
```

```
Plot3D[Sin[x] Cos[y] -
Cos[x] Sin[y],
{x,-2Pi,2Pi},{y,-2Pi,2Pi}]
```

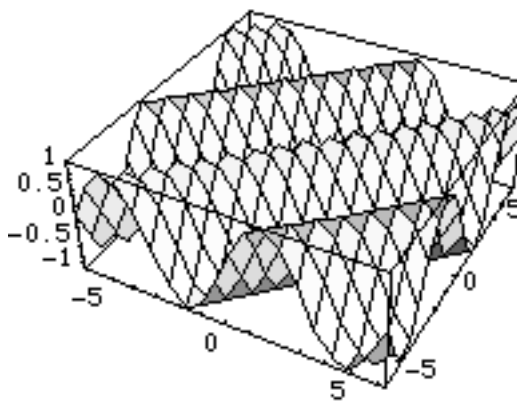

```
Plot3D[Cos[x+y],
  {x,-2Pi,2Pi},{y,-2Pi,2Pi}]
```

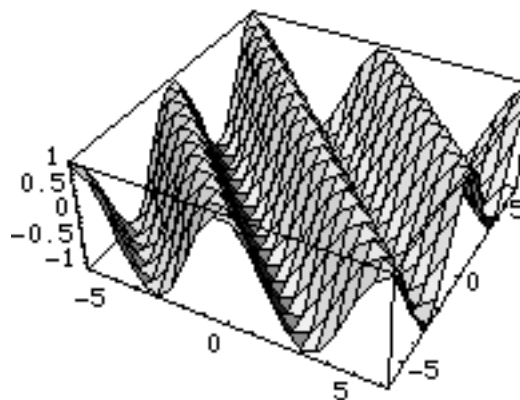

```
Plot3D[Cos[x] Cos[y] -
  Sin[x] Sin[y],
  {x,-2Pi,2Pi},{y,-2Pi,2Pi}]
```

```
Plot3D[Cos[x-y],
  {x,-2Pi,2Pi},{y,-2Pi,2Pi}]
```

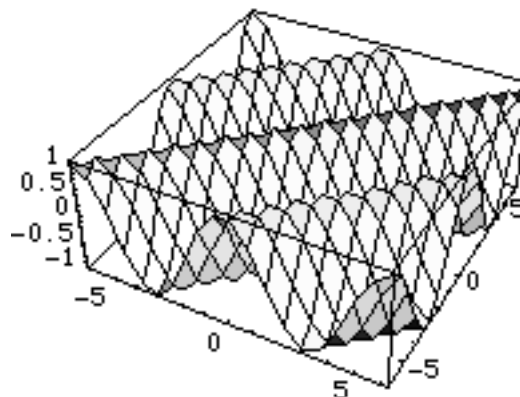

```
Plot3D[Cos[x] Cos[y] +
  Sin[x] Sin[y],
  {x,-2Pi,2Pi},{y,-2Pi,2Pi}]
```

```
Plot3D[Tan[x+y],
  {x,-Pi/4,Pi/4},
  {y,-Pi/4,Pi/4},
  ViewPoint->{2.284,-2.325,0.910}]
```

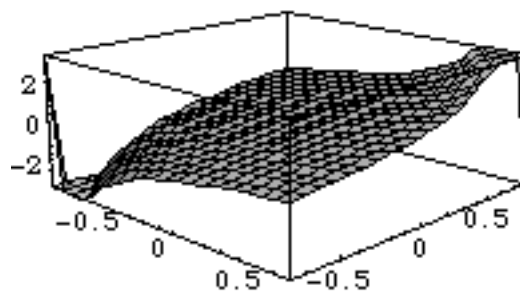

```
Plot3D[(Tan[x]+Tan[y])
/(1-Tan[x]Tan[x]),
  {x,-Pi/4,Pi/4},
  {y,-Pi/4,Pi/4},
  ViewPoint->{2.284,-2.325,0.910}]
```

```
Plot3D[Tan[x-y],
  {x,-Pi/4,Pi/4},
  {y,-Pi/4,Pi/4},
  ViewPoint->{2.284,-2.325,0.910}]
```

```
Plot3D[(Tan[x]-Tan[y])
  /(1+Tan[x]Tan[x]),
  {x,-Pi/4,Pi/4},
  {y,-Pi/4,Pi/4},
  ViewPoint->{2.284,-2.325,0.910}]
```

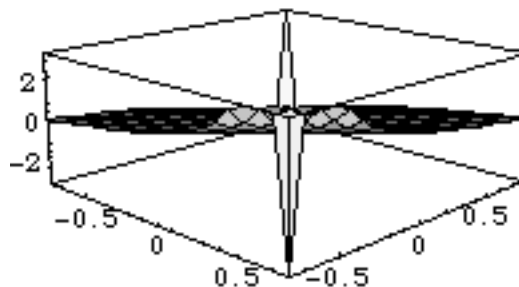

What if you use the incorrect sign?

```
Plot3D[Sin[x-y],
  {x,-2Pi,2Pi},{y,-2Pi,2Pi}]
```

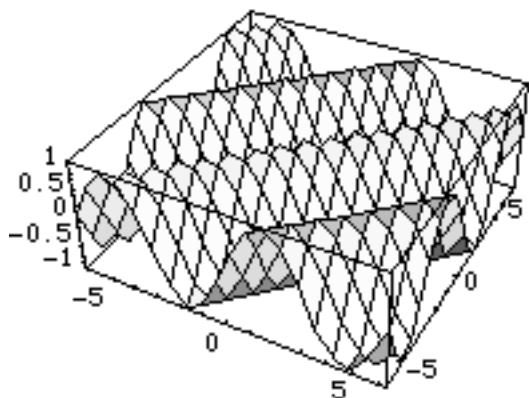

≠

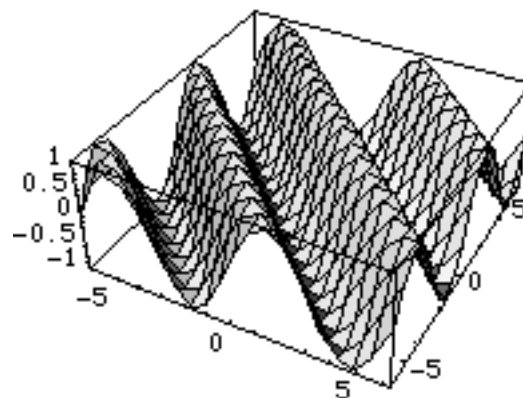

```
Plot3D[Sin[x] Cos[y] +
  Cos[x] Sin[y],
  {x,-2Pi,2Pi},{y,-2Pi,2Pi}]
```

In addition to trigonometry identities, *Mathematica* has tremendous potential for similarly representing logarithmic identities. The graphs of $\log xy$, $\log x + \log y$, $\log \frac{x}{y}$, and $\log x - \log y$ serve as powerful motivators for helping students "believe" that:

$$\log xy = \log x + \log y$$

$$\log \frac{x}{y} = \log x - \log y$$

```
Plot3D[Log[x y],
  {x,0.1,2},{y,0.1,2},
  ViewPoint->{2.191,-2.231,1.294}]
```

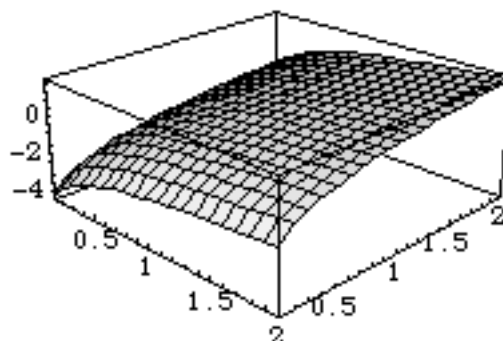

```
Plot3D[Log[x] + Log[y],
  {x,0.1,2},{y,0.1,2},
  ViewPoint->{2.191,-2.231,1.294}]
```

```
Plot3D[Log[x/y],
  {x,0.1,2},{y,0.1,2},
  ViewPoint->{1.797,-2.646,1.104}]
```

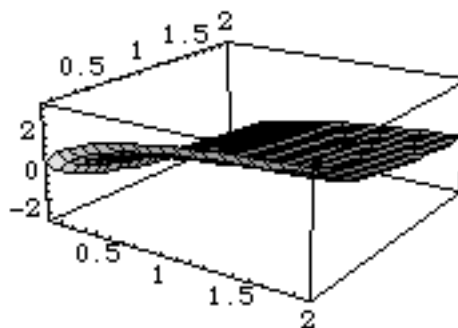

```
Plot3D[Log[x] + Log[y],
  {x,0.1,2},{y,0.1,2},
  ViewPoint->{1.797,-2.646,1.104}]
```

It should be noted that the use of technology does not verify or validate the identities. Students still need to prove or verify that the identities do exist. The technology serve as a powerful visual aid to help the student bridge the gap between the conjectured form of the identity and the actual verification of the identity. 🐼